

Verbindungselemente · Connection elements · Éléments de jonction

T-Verbinder T-connector Joint en T

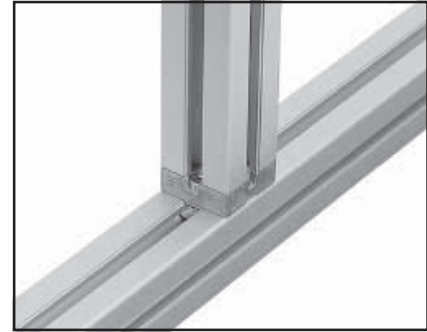

00111527



T-Verbinder mit selbstschneidenden Schrauben für die rechtwinklige Verbindung von Profilen.

Keine Endenbearbeitung!

Material

- Aluminiumdruckguss
- 45x45: Zinkdruckguss

T-connector with self-tapping screws for right-angled profile connections.

No end finishing!

Material

- diecast aluminum
- 45x45: diecast zinc

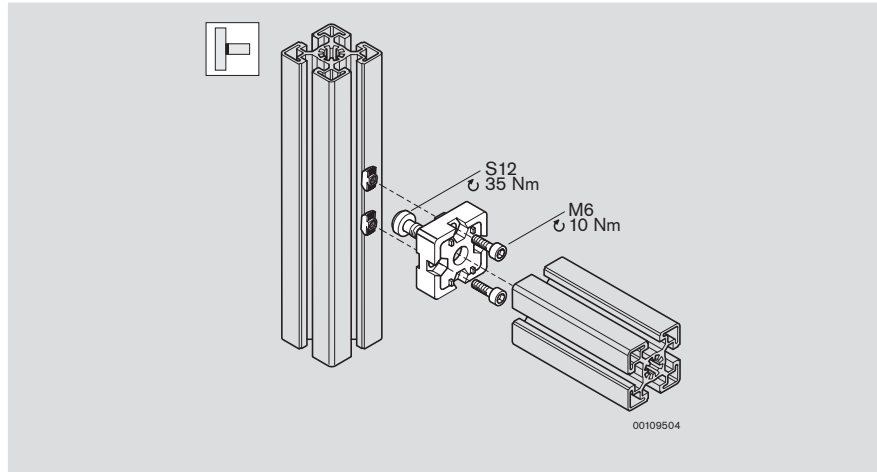

Joint en T avec vis taraudeuses pour la liaison rectangulaire des profilés.

Pas d'usinage des extrémités !

Matériau

- aluminium coulé sous pression
- 45x45 : zinc moulé sous pression

30x30

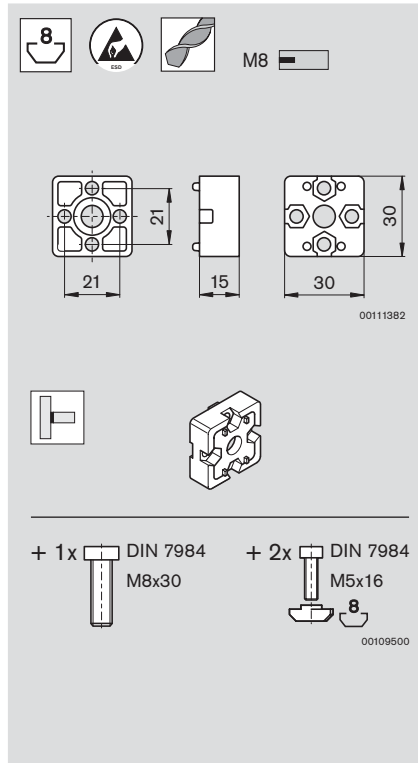

Nr./No./N°
30x30 3 842 524 476

40x40

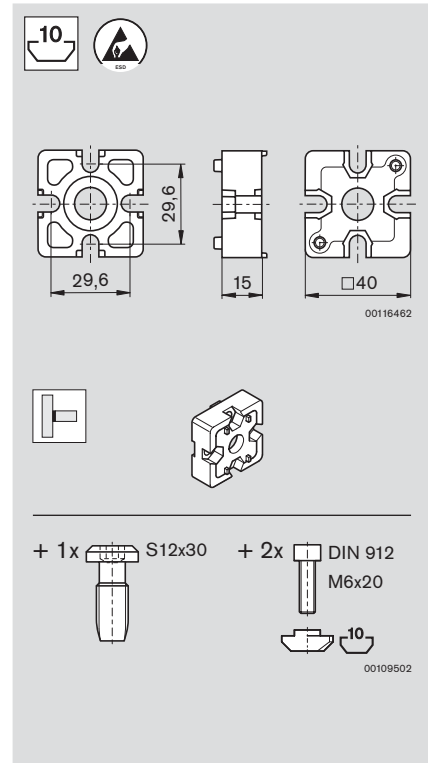

Nr./No./N°
40x40 3 842 532 195

Verbindungselemente · Connection elements · Éléments de jonction



45x45

00111383

+ 1x S12x30 + 2x DIN 912 M6x20

00109502

	Nr./No./N°
45x45	3 842 520 802

50x50

00116463

+ 1x S12x30 + 2x DIN 912 M6x20

00109502

	Nr./No./N°
50x50	3 842 532 198