

Gewindehülse, Bodendübel, Unterlegscheibe Threaded sleeve, floor dowel, shim Manchon fileté, chevilles de sol, rondelle



Die Gewindehülse dient zur Befestigung von Gelenkfüßen quer zur Profillängsrichtung.

Material:
– Stahl verzinkt.

Bodendübel (A) zum sicheren Verankern der Fußplatten am Boden.
Unterlegscheibe (B) zum senkrechten Ausrichten bei Bodenunebenheiten.

Material:
– A: Stahl, verzinkt
– B: nichtrostender Stahl

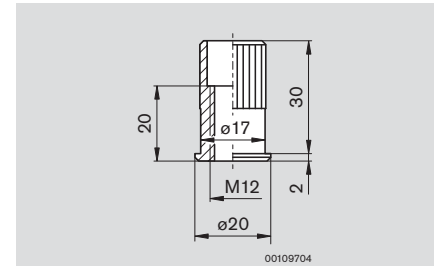
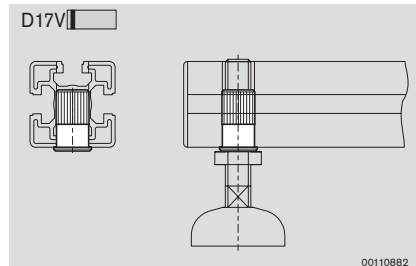

Nr./No./N°
3 842 504 790

The threaded sleeve is used to attach hinged feet at right angles to a profile.

Material:
– galvanized steel.

Floor dowel (A) for anchoring base plates securely to the floor.
Shim (B) for vertical alignment on uneven floors.

Material:
– A: galvanized steel
– B: stainless steel

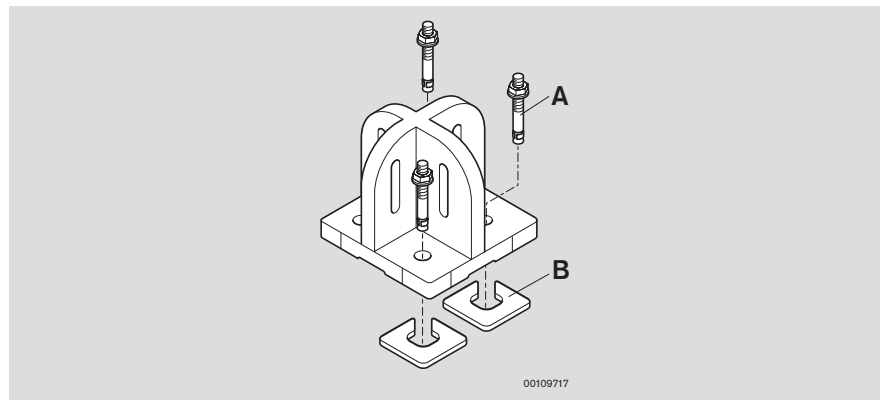

Le manchon fileté sert de fixation pour les pieds articulés, transversalement au sens longitudinal du profilé.

Matériau:
– acier galvanisé.

Cheville de sol (A) pour l'ancrage sûr des semelles au sol.
Rondelle (B) pour l'orientation verticale en cas d'inégalités du sol.

Matériau :
– A : Acier, galvanisé
– B : acier inoxydable

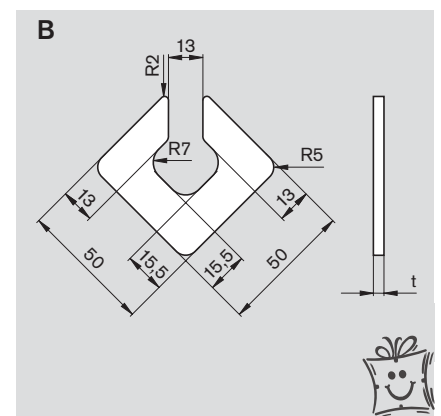
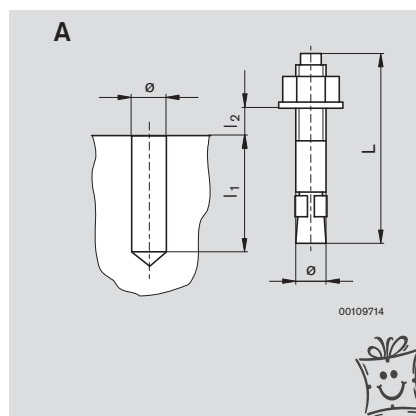

ø	L	l ₁	l ₂	Nr./No./N°
8	76	73	10-23	3 842 526 560
10	89	83	15-23	3 842 526 561

t	Nr./No./N°
1	3 842 528 189
4	3 842 528 191

